

浙江步步精电子有限公司

承认书

客户名称: _____

品名规格 12x12x6贴片260gf长脚

客户料号: _____

执行标准: _____

制造厂商: 浙江步步精电子有限公司

送样日期: _____

拟制	工程	品质	批准
陈志庚	杨凌辉	朱林义	

客户承认

工程	品质	审核	批准

认证编号:

公司全称:

联系人:

联系人 E-mail: sz-bbj@163.com

电话: 0755-82886755

传真: 0755-83214466

网站: www.cnbbj.com

地址: 深圳市宝安区福永街道大洋田福

安第二工业区 7 栋四楼

浙江步步精电子有限公司

目录

封面	(1)
目录	(2)
图纸	(3)
产品各规格参数	(4-6)

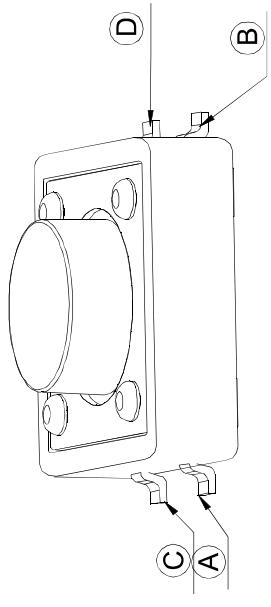
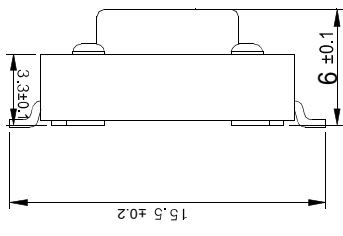
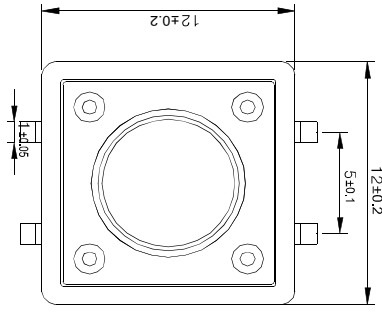

1. Rating: DC12V 50mA
2. Travel: 0.25 ± 0.1mm.
3. Operating Force: 260 ± 50gf
4. Contact Resistance: 50m ΩMax.
5. Life: 100000 Cycles Min.

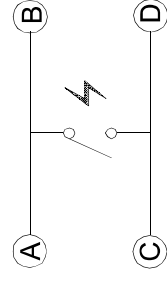
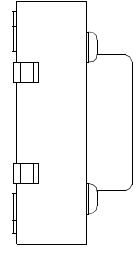

电路简图
SCHEMATIC

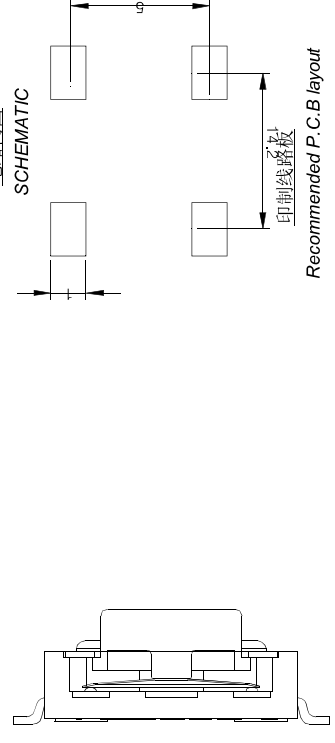

印制线路板
Recommended P. C. B layout

6	平盖板	黄铜	银色	镀锡	
5	帽头	PPA	黑色		
4	簧片	复银铜		材料进口	
3	底座	PPA	黑色		
2	嵌件	黄铜	银色	镀银	
1	序号	名称	材料	颜色	备注
NO.	DESCRIPTION	MATERIAL	COLOR	REMARK	

浙江步精电子有限公司

CUSTOMER COPY	12x12x9.5贴片260gf长脚
型号	
TYPE NO.	
料号	
PART NO.(OLD)	
图号	A
DRAWING NO.	
SCALE	3:1
UNIT	mm
	A4

更改	承认	Angle	±2°	DRAW	制图
CHANGE	APPRO.	30 ~	±0.5	DESIGN	设计
		10-30	±0.3	CHECCH	校核
		-10	±0.15	APPRO.	承认
			UNLESS OTHERWISE NOTED		
ECN(DCN) NO.	REV	日期	说明	描述	DESCRIPTION
PO	07/11/08				
工程变更通知单	版次	日期	说明	描述	DESCRIPTION

071108-01

ZHE JIANG BU BU JING ELECTRONIC COMPONENTS CO LTD 浙江步步精电子有限公司		DOCUMENT NUMBER 文件编号		
		DATE 日期		
SPECIFICATION 规格书		PAGE 页数		共 3 页 第 1 页
MODEL NO. 产品名称: 轻触开关				
ORGANIZER 编制		AUDITING 审核		AUTHORIZE 批准
1. RATING (额定值) :DC 12V 50mA				
2. ELECTRICAL CHARACTERISTICS(电气性能规格):				
	ITEM 项目	TEST CONDITIONS 测试条件		PERFORMANCE 规格
2.1	CONTACT RESISTANCE 接触电阻	MEASURED AT SMALL CURRENT (100mA OR LESS) 在微小电流 (100mA) 以下测试。		30mΩ MAX 30毫欧以下。
2.2	INSULATION RESISTANCE 绝缘电阻	APPLY A VOLTAGE OF 100V DC FOR 1 MIN, TO FOLLOWING PORTIONS AFTER WHICH MEASUREMENT SHALL BE MADE. (1) BETWEEN BODY AND CONDUCTOR (2) BETWEEN CONDUCTORS NOT TO BE CONTACT. 输入100V DC 电压1分钟, 按以下接触方法测试: (1) 接触端子之间 (2) 胶座与排脚之间		100MΩ MIN 100兆欧以上
2.3	DIELECTRIC STRENGTH 耐电压	AC 250V (50-60Hz) FOR 1 MIN TRIP CURRENT: 0.5mA (1) BETWEEN TERMINALS. (2) BETWEEN INDIVIDUAL TERMINALS AND FRAME. 输入AC 250V (50-60Hz) 电压, 1分钟电流为0.5mA, 按 以下接触方式测试 (1) 排脚相互之间 (2) 排脚与外壳之间		WITHOUT DAMAGE TO PARTS ARCING OR BREAKDOWN ETC. 没有绝缘破坏等异常。
3. MECHANICAL CHARACTERISTICS (机械性能规格)				
	ITEM 项目	TEST CONDITIONS 测试条件		PERFORMANCE 规格
3.1	OPERATING FORCE 操作力	SWITCH IS PLACED VERTICALLY, THE TOP OF THE WHOLE TRIP TEST ACCORDING TO THE STRENGTH 开关垂直放置, 测试顶端按至全行程后的力度		260±50gf
3.2	Return Force 回弹力	SWITCH IS PLACED VERTICALLY, TEST THE TOP ACCORDING TO TOTAL TRAVEL BACK TO FREE UP EFFORTS 开关垂直放置, 测试顶端按至全行程后恢复到自由为止的力度		40gf. min.
3.3	TERMINAL STRENGTH 端子强度	A STATIC LOAD OF (300gf) SHALL BE APPLIED TO THE TIP OF THE TERMINAL FOR 1 MIN IN ANY DIRECTION 在任意一个方向的先端加上 (300gf) 力度测试, 时 间1分钟。		ELECTRICAL CHARACTERISTICS SHALL BE SATISFIED WITHOUT DAMAGE OR EXCESSIVE LOOSENESS OF ACTUATOR 端子没有裂开、松动 等异常, 满足机械、 电性能要求
3.4	PRACTICAL TEMPERATURE RANGE 使用温度范围	-16°C ~ +60°C 在-16°C ~ +60°C 温度内使用		

ZHE JIANG BU BU JING ELECTRONIC COMPONENTS CO LTD 浙江步步精电子有限公司		DOCUMENT NUMBER 文件编号	
		DATE 日期	
SPECIFICATION 规格书		PAGE 页数	共 3 页 第 2 页
	ITEM 项目	TEST CONDITIONS 测试条件	PERFORMANCE 规格
3.4	STANDARD ATMOSPHERIC CONDITIONS 测试标准状态	UNLESS OTHERWISE SPECIFIED, THE STANDARD RANGE OF ATMOSPHERIC CONDITIONS FOR MAKING MEASUREMENTS AND TESTS ARE AS FOLLOWS: (1) AMBIENT TEMPERATURE: 5°C TO 35°C (2) RELATIVE HUMIDITY: 45% TO 85% (3) AIR PRESSURE : 80Kpa TO 106Kpa 在没有指定的情况下测试温度、湿度、气压如下: (1) 温度为5°C~35°C (2) 湿度为45%~85% (3) 气压为80Kpa~106Kpa	
4. DURABILITY (耐久性):			
4.1	LIFE TEST 寿命试验	WITHOUT LOAD: AN ACTUATOR SHALL BE SUBJECT TO 100000 CYCLES AT A SPEED OF 2~3 CYCLES FOR 1 SECONDS 无负荷: 操作者以每秒 2~3 次的频率作 100000 回无负荷测试	(1) CONTACT RESISTANCE SHALL BE 200mΩ MAX (2) MECHANICAL AND ELECTRICAL CHARACTERISTICS SHALL BE SATISFIED. (1) 接触电阻不能超过 200mΩ (2) 其它因满足机械、电性能要求
4.2	HEAT TEST 耐热试验	THE SWITCH SHALL BE STORED AT A TEMPERATURE OF 85±2°C FOR 96 HOURS . AND THEN IT SHALL BE SUBJECTED TO THE CONTROLLED RECOVERY CONDITIONS FOR 1 HOUR AFTER WHICH MEASUREMENT SHALL BE MADE. 放置在温度 85°C 中测试 96 小时后, 再放置正常室温中 1 小时后测定	THERE SHALL BE NO DAMAGE ON APPEARANCE. MECHANICAL AND ELECTRICAL CHARACTERISTICS SHALL BE SATISFIED. 外观无异常, 满足机械、电性能要求
4.3	COLD TEST 耐冷试验	THE SWITCH SHALL BE STORED AT A TEMPERATURE OF -25±3°C FOR 96 HOURS . AND THEN IT SHALL BE SUBJECTED TO THE CONTROLLED RECOVER CONDITIONS FOR 1 HOURS AFTER WHICH MEASUREMENT SHALL BE MADE. 放置在温度 -25±3°C 中 96 小时, 再放置常温中 1 小时后测定。	THERE SHALL BE NO DEFORMATION OR CRACKS IN MOLDED PART. 外观无异常, 满足机械、电性能要求
4.4	HOMIDITY TEST 潮湿试验	THE SWITCH SHALL BE STORED AT A TEMPERATURE OF 40±2°C AND A HUMIFITY OF 90% TO 96% FOR 96 HOURS . THEN THE SWITCH SHALL BE MAINTAINED AT STANDARD ATMOSPHERIC CONDITION FOR 1 HR FOR OTHER PROCEDURES BE MADE. 放置 40±2°C 相对湿度为 90~96% 环境中 96 小时后, 再放置常温中 1 小时后测定。	

ZHE JIANG BU BU JING ELECTRONIC COMPONENTS CO LTD 浙江步步精电子有限公司		DOCUMENT NUMBER 文件编号	
		DATE 日期	
SPECIFICATION 规格书		PAGE 页数	共 3 页 第 3 页
	ITEM 项目	TEST CONDITIONS 测试条件	PERFORMANCE 规格
4.5	SOLDERING CONDITIONS 焊锡条件	<p>HAND SOLDERING: (1) DEVICE: SOLDER IRON A. 350°C MAX . 3SEC MAX B. 270°C MAX . 5SEC MAX (2) REFLOW SOLDERING 手焊 (1) 工具: 烙铁 A. 350°C MAX . 3SEC MAX 不能对焊脚加压 B. 270°C MAX . 5SEC MAX (2) 回流焊</p>	<p>THERE SHALL BE NO DEFORMATION OR CRACKS IN MOLDED PART. 外观无异常, 满足机械、电性能要求</p>